

■ LTCC 天线

LTCC antenna

◆ 特征

Feature

- * 小尺寸
Small size
- * 宽温度使用范围
Temperature stable
- * LTCC 结构，具备良好的耐湿性、耐腐蚀性、高可靠性
LTCC construction, and has good moisture resistance, corrosion resistance, high reliability.
- * 符合 RoHS 指令和无卤素要求
Compliant with RoHS directive and Halogen free requirement.



◆ 应用

Application

- * 物联网终端
IoT terminal
- * 高频/甚高频 收发使用等
VHF/UHF transmitters/receivers

◆ 型号表示法

Part Number

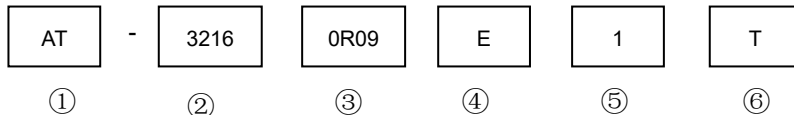

- ① 表示产品代号（2 位数）：“AT”代表天线。
Indicates the product code (2 digits): "AT" stands for antenna
- ② 表示产品外形尺寸（4 位数）：如公制 3216 尺寸等。
Indicates the overall dimension of the product (4 digits): such as the metric 3216 size.
- ③ 表示产品工作频率（4 位数）：天线使用 GHz 单位，“R”代表小数点。
Represents product operating frequency (4 digits): antenna uses GHz unit, and "R" represents decimal point.
- ④ 表示外部电极实现方式（1 位字母）：参照附件 1 产品型号外部电极实现方式。
Indicate the external electrode realization method (1-digit letter): refer to Appendix 1 Product Model External Electrode Realization Method.
- ⑤ 表示产品设计（1 位数）：数字“1”代表常规、以数字“2”开始依次往后编排阿拉伯数字或者字母代表不同类型的特殊定制。
Represent product design (1 digit): the number "1" represents the general, and the number "2" starts with the Arabic numerals or letters to represent different types of special customization.
- ⑥ 表示包装方式（1 位字母）：“T”代表编带包装，“B”代表塑料盒包装，“C”代表塑料袋包装。
Indicates the packaging method (1 digit letter): "T" represents ribbon packaging, "B" represents plastic box packaging, and "C" represents plastic bag packaging.

◆ 产品规格尺寸

Product Dimension

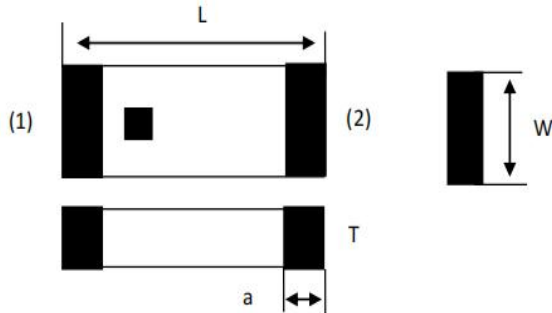
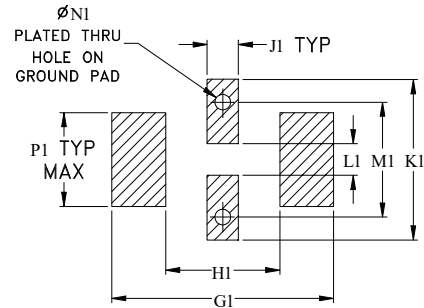
*** B 形外电极方式的产品尺寸**
B-shaped outer electrode method product size

*** PCB 焊盘样式**
PCB Land Pattern

 Suggested Layout,
 Tolerance to be within ± 0.05

| L | W | T | a |
|---------|---------|--------|-----------|
| 3.2±0.2 | 1.6±0.2 | 1.2max | 0.25±0.10 |

* Unit:mm

| | |
|-----------------------|------|
| 输入 Input Port | (1) |
| 接地 GND | None |
| 输出 Soldering terminal | (2) |

* Pin Connections

◆ 最大额定值

Maximum Ratings

| | |
|----------------------------|-------------------------------------|
| 类型 Type | 天线(3216)antenna |
| 工作温度 Operating Temperature | -55°C to 100°C |
| 储存温度 Storage Temperature | -55°C to 100°C |
| 射频输入功率 RF Power Input* | 2W max. at25°C 1.0W max. at100°C |

* Permanent damage may occur if any of these limits are exceeded.

◆ 电性能参数规格

Electrical Specification at 25°C

| 产品型号 | 工作频率段 | | | | 阻抗 Ω |
|----------------|-------------|---------------|--------|------------|---------|
| | 工作频率 MHz | 增益dBi Typ. | 极化方向 | 驻波比 MAX | |
| AT-32162R45E1T | 2400~2500 | 2 | Linear | 2 | 50 |
| AT-32162R45E2T | 2400~2500 | 2 | Linear | 2.2 | 50 |

* Measured on Fenghua Characterization Test Board.

◆ 产品特性曲线图

Product Characteristic Curve

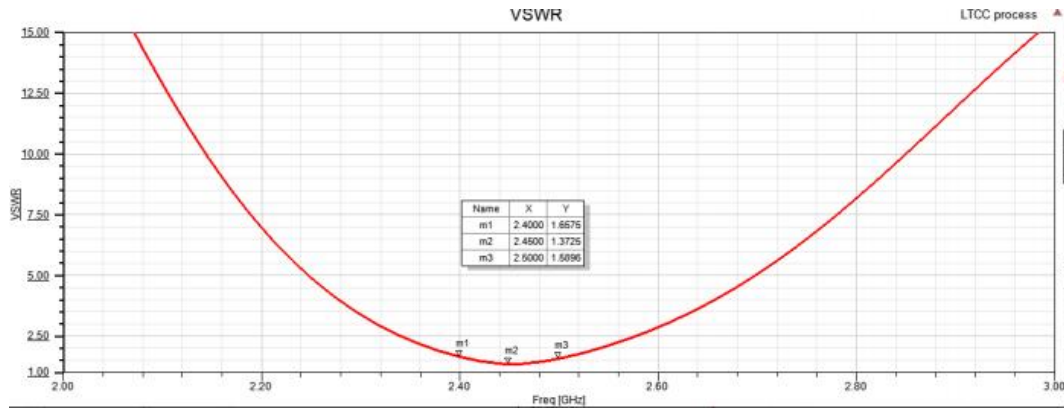

附录 Appendix

◆ 推荐的 PCB 布线:

Suggested PCB layout:

* E 形外电极方式产品:

E-shaped outer electrode method products:

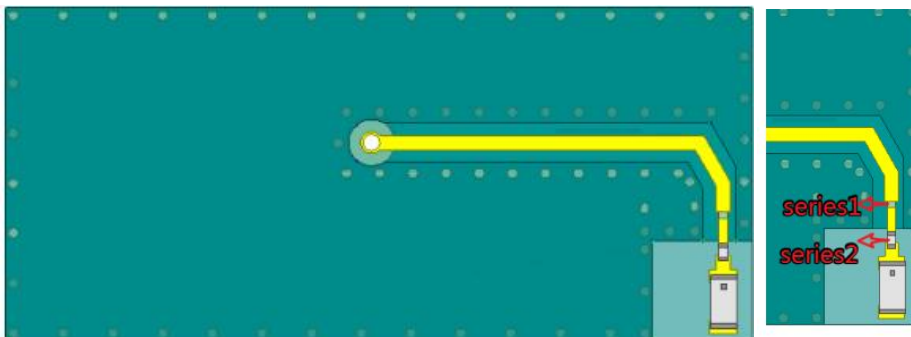

| | Component |
|-----------------|----------------|
| Matching | Series1: / |
| component value | Series2: 6.8nH |

注: 1. 如图所示为罗杰斯 R04350B 板材的共面波导参数, 厚度为 $0.508 \pm 0.038\text{mm}$ 。覆铜厚度: 每面 1/2 盎司。对于其他板材, 馈线宽度和间隙可能需要修改。Coplanar wave guide parameters are shown for Rogers RO4350B with thickness $0.508 \pm 0.038\text{mm}$. Copper: 1/2 OZ.each side. For other materials trace width & gap may need to be modified.

2. PCB 底面为连续接地层。Bottom side of the pcb is continuous ground plane.

 表示带 SMOBC 的 PCB 铜布局 (裸铜上的阻焊层) Denotes pcb copper layout with smobc. (solder mask over bare copper)

 表示不含阻焊层的铜焊盘图案。Denotes copper land pattern free of solder mask.

◆ 包装
Packaging

* 塑料带编带 Embossed Taping

适用于2012、3216:

For 2012、3216:

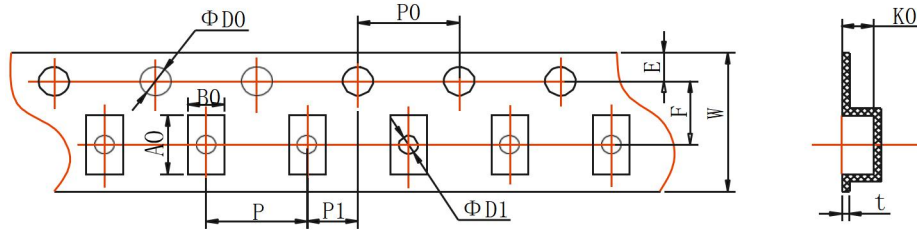

单位 unit: mm

| 型号 Type | A0 | B0 | W | F | E | t |
|---------|-----------|-----------|-----------|-----------|-----------|-----------|
| 2012 | 2.35±0.10 | 1.65±0.10 | 8.00±0.20 | 3.50±0.05 | 1.75±0.10 | 0.25±0.05 |
| 3216 | 3.50±0.20 | 1.90±0.20 | 8.00±0.20 | 3.50±0.05 | 1.75±0.10 | 0.25±0.05 |

| 型号 Type | P | P0 | P1 | ΦD0 | ΦD1 | K0 |
|---------|-----------|-----------|-----------|--------------|-----------|-----------|
| 2012 | 4.00±0.10 | 4.00±0.10 | 2.00±0.05 | 1.50+0.10/-0 | 1.50±0.10 | 1.00±0.10 |
| 3216 | 4.00±0.10 | 4.00±0.10 | 2.00±0.05 | 1.50+0.10/-0 | 1.50±0.10 | 1.20±0.10 |

* 卷盘 Reel

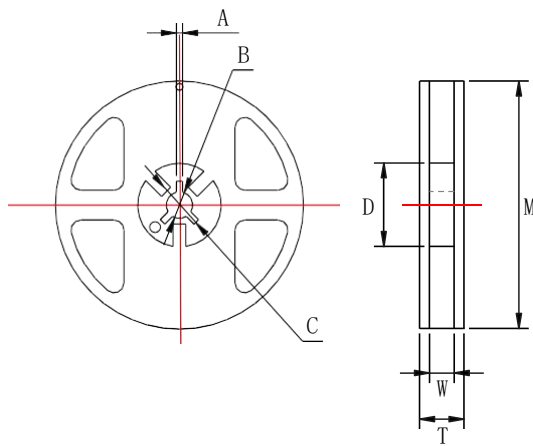

单位 unit: mm

| 型号 Type | M | W | T | A | B | C | D |
|-----------|---------|----------|----------|---------|----------|----------|----------|
| 2012、3216 | 178±2.0 | 13.0±0.5 | 15.5±1.5 | 2.0±0.5 | 13.0±0.5 | 21.0±0.5 | 57.0±2.0 |

* 编带包装能力 Taping Ability

面带拉力 Top tape peel strength

面带拉力强度为 11~70g (0.1N~0.7N)，速度：300mm/min,经下列试验后不允许有破裂断带现象。

Peel strength is 11~70g (0.1N~0.7N),with speed of 300mm/min,and should not have flash and tear after peeling.

测试方法 Test method:

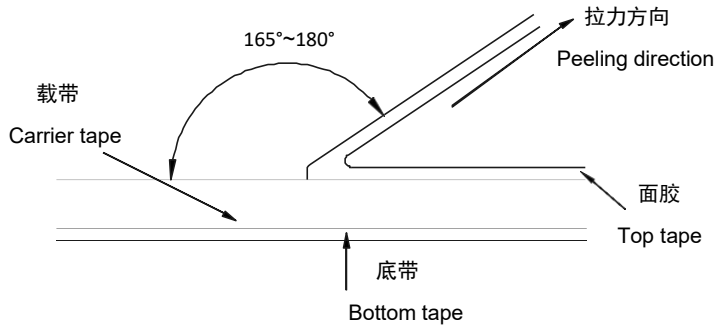

产品松动自如，无粘面胶带、底胶带现象。

Filter is free, no sticking to top tape and bottom tape.

产品易从载带中取出，且产品孔无机械损伤。

Filter is easy to take out from carrier tape and chip hole have no mechanical damage.

* 包装数量 Packaging Quantity

| 包装方法 Packaging style | 编带 Tape & reel | 塑料袋散装 Case |
|-------------------------|-------------------|---------------|
| 型号 Type | 2012、3216 | 2012、3216 |
| 数量 Quantity(pcs) | ≤3000 | ≤10000 |

◆ LTCC 天线使用说明

LTCC Antenna Instructions for Use

* 本产品在以下特殊环境下应用，性能可能会受到影响：

Application of the products in a special environment can deteriorate product performance:

- 1、在各种类型的液体，包括水、油、化学品、有机溶剂的使用。
Use in various types of liquid, including water, oils, chemicals, and organic solvents.
- 2、在户外直接暴露在阳光的地方，或在灰尘多的地方使用。
Use outdoors where the products are exposed to direct sunlight, or in dusty places.
- 3、在产品暴露的地方，有海风或腐蚀性气体，包括氯气、硫化氢、氨气、二氧化硫、二氧化氮等。
Use in places where the products are exposed to sea winds or corrosive gases, including Cl₂, H₂S, Nh₃, SO₂, and No₂ etc.
- 4、在产品暴露于静电或强电磁波的地方使用。
Use in places where the products are exposed to static electricity or strong electromagnetic waves.
- 5、在产生热量的部件、塑料线，或其他易燃物品附近使用。
Use in proximity to heat-producing components, plastic cords, or other flammable items.
- 6、在用树脂或其他涂层材料密封产品的情况下使用。
Use involving sealing or coating the products with resin or other coating materials.
- 7、焊接后使用不洁焊料或使用水或水溶性清洗剂清洗产品。

Use involving unclean solder or use of water or water-soluble cleaning agents for cleaning after soldering.

- 8、片式天线的基材主要是氧化铝和玻璃。由于和安装基板的热膨胀系数不同，在反复施加提供热循环等热应力时，接合部的焊锡（焊缝部）有时会发生裂纹。如果环境温度反复发生很大的变动，并且载荷反复进行 ON/OFF，则需要注意龟裂的发生。因热应力而发生的龟裂，取决于所安装的焊盘的大小、焊锡量、安装基板的散热性等，因此在环境温度有很大的变化或载荷 ON/OFF 的条件下使用时，请充分注意以进行设计。

The substrate of chip antenna are mainly alumina and glass. Cracks may occur at the connection of solder (solder fillet portion) due to the difference of the coefficient of thermal expansion from a mounting board when heat stress like heat cycle, etc. are repeatedly given to them. Care should be taken to the occurrence of the cracks when the change in ambient temperature or ON/OFF of load is repeated. The occurrence of the crack by heat stress may be influenced by the size of a pad, solder volume, heat radiation of mounting board etc., so please pay careful attention to designing when a big change in ambient temperature and conditions for use like ON/OFF of load can be assumed.

◆ 产品使用注意事项

Precautions on use of products

- 1、避免采用超过正常额定功率的功率，超过额定功率的稳态负载条件下可能会对产品性能和可靠性产生负面影响。
 Avoid applying power exceeding normal rated power, exceeding the power rating under steady-state loading condition may negatively affect product performance and reliability.
- 2、用镊子拿起产品时要小心，有可能会将保护或电阻体夹碎。
 Be careful when pick up the products with tweezers. There may be a care that the overcoat and other body can be chipped.
- 3、手动安装产品时，烙铁头勿触碰产品。
 Soldering tip shall not touch the product when install product manually.
- 4、建议贮存条件：温度 5℃~30℃，相对湿度 30%~70%。
 建议在符合上述储存条件下六个月内使用。
 Storage conditions: T: 5℃ ~ 30℃ , RH: 30% ~ 70%. The products are suggested to be used within six months when received, and the storage condition mentioned above should be followed.
- 5、用于车载设备、医疗设备、航空设备以及其它涉及人身安全、或可能引起重大损失的设备上时，请务必事先与我公司联系。这些产品在这类用途中出现故障或失灵可能导致人身事故或严重损坏。
 Contact our sales representatives before you use our products for applications including automotive, medical equipment and aerospace equipment. Malfunction or failure of the products in such applications may cause loss of human life or serious damage.

◆ 焊接 Soldering

* 推荐的回流焊曲线 Recommended reflow profile

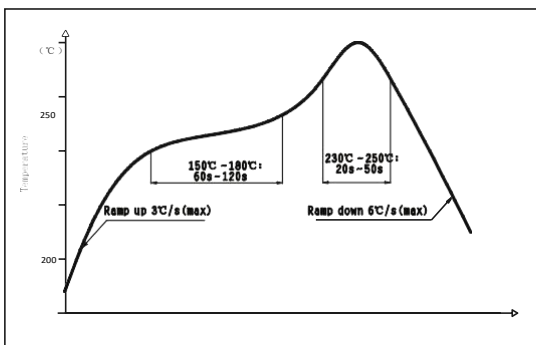

* 推荐的波峰焊曲线 Recommended wave solder profile

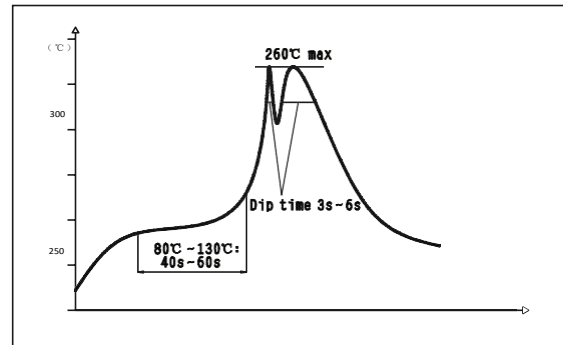

* 推荐的焊膏类型 Recommended solder alloy: 96.5Sn/3.0Ag/0.5Cu.